

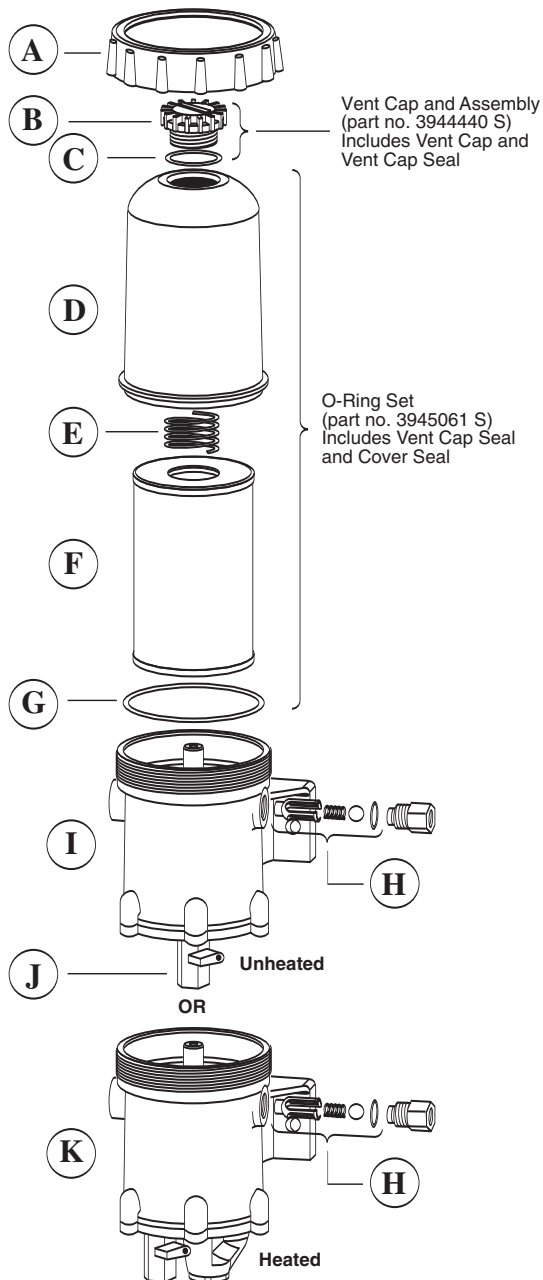

Fuel Pro[®] Installation Instructions

FH230 Series Filter / Separator / Warmer



- A. Collar (part no. 3944445 S)
- B. Vent Cap
- C. O-Ring
- D. Body Housing (part no. 3944443 S)
- E. Holddown Spring (part no. 3944441 S)
- F. Filter Element (see Table 1 for ordering information)
- G. O-Ring Pac (part no. 3944449 S)
- H. Check Valve Service Kit (part no. 3944447 S)
- I. Fuel Pro, Unheated (see page 6 for ordering information)
- J. Drain Valve (part no. 3944453 S)
- K. Fuel Pro, Heated (see page 6 for ordering information)

CAUTION: These instructions are intended for use by professional mechanics who are trained in the proper use of power and hand tools, using appropriate safety precautions (including eye protection).

Service Kit Installation

This system is installed between the fuel tank and the fuel pump after the primary fuel filter adapter head is removed and a special diverter cap is installed on the secondary filter head. Diverter caps are sold separately and are not part of the Fuel Pro service kit. The diverter caps available for use with this kit are listed in Table 1. This system is designed to be the **only fuel filter** in the fuel system.

Table 1 - Diverter Cap Part Numbers

Diverter Cap Part Number	Required Filter Head Stud Size	Required Filter Head Seal ID	Required Filter Head Seal OD
3945182 S	1"-14	2.475"	2.895"
3945183 S	1"-14	3.225"	3.435"
3945184 S	M6 x 1.5	2.475"	2.895"
3945185 S	3/4" x 16	2.475"	2.895"
3945186 S	7/8" x 14	2.475"	2.895"
3945187 S	M18 x 1.5	2.475"	2.895"
3945188 S	13/16" x 12	3.225"	3.235"

WARNING: When diesel fuel is circulated through an operating engine, it can become very hot. To prevent personal injury:

- **Scalding hazard! Do not allow heated liquid fuel to come in contact with eyes or unprotected skin. Always allow the engine and fuel to cool to ambient temperature before replacing the fuel filter or performing service operations which could result in the spillage of fuel from the fuel system. If this is not possible, protective clothing (face shield, insulated hat, gloves, apron) must be worn.**
- **Heated diesel fuel can form combustible vapor mixtures in the area around the fuel source. To eliminate the potential for fire, keep open flames, sparks or other potential ignition sources away from the work area, and do not smoke during filter replacement or service operations which could result in the escape of diesel fuel or fuel vapors.**
- **Always perform engine or vehicle fuel system maintenance in a well ventilated area that is kept free of bystanders.**

Installation of the Fuel Pro Service Kit

Step 1 - With the engine shut down and at ambient temperature, close the fuel shutoff valve (if equipped) and place a suitable container under the fuel filters.

Step 2 - Remove the primary fuel filter element assembly, sedimenter, and/or water separator. Drain the used element and dispose of it in an environmentally responsible manner, according to state and/or federal (EPA) recommendations. The fuel can be returned to the tank.

Step 3 - Remove the secondary filter, if applicable, and do one of the following:

- Replace the filter with a fuel diverter cap.
- Remove the filter head and connect the fuel hoses together.

Step 4 - Mount the Fuel Pro in the desired location keeping the following points in mind:

- Mounting the Fuel Pro directly on the engine is NOT RECOMMENDED.**
- Mount vertically with the cover and element pointing up.
- Make sure there is enough top and side clearance for the cover to be conveniently removed for filter replacement.

CAUTION: The Fuel Pro **MUST** be installed so that the Filter Element is above the "FULL" level of the fuel tank.

Step 5 - Route the fuel supply line from the fuel tank to the Fuel Pro inlet (Figure 1). Route a fuel line from the Fuel Pro outlet to the fuel pump inlet.

Step 6 - To minimize restrictions, observe the following guidelines when plumbing the system.

- Keep the fuel line routing as smooth as possible with no low hanging loops which can trap water.
- Use 90° elbows only when necessary.

- c. If the fuel hoses are made up to length on the job, be sure that the inner liner of the fuel hose is not cut by the fitting, creating potential check valve effects. Also make sure hoses are clean and free of debris before installing.

CAUTION: To avoid damaging the aluminum fuel processor body, do not overtighten fuel lines or fuel line fittings.

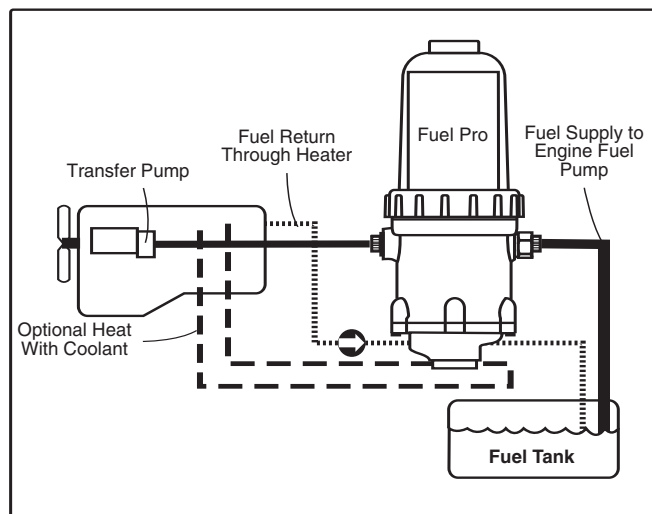

Figure 1 - Fuel Pro Connections

Fuel Heating Options

Note: The Engine Return Fuel Heat and Engine Coolant Heat options apply **ONLY** to the heater base shown in Figure 2. If the bottom plate is flat with 1/2" NPT ports, only the Electric Preheater can be used.

Engine Return Fuel Heat

Electronic unit injected engines can use return fuel as the fluid heat for the Fuel Pro. Route the return fuel line from the engine into the Heater Base of the Fuel Pro (see Figure 2). Either heater port will work as an inlet. Connect a second fuel return line from the Heater Base to the fuel tank return port.

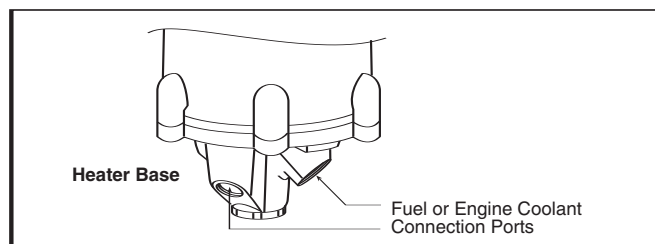

Figure 2 - Heater Base

Engine Coolant Heat

To use engine coolant as the Fuel Pro heating fluid, connect a hose (Braided #6 or #8 hose) from the high pressure side of the engine coolant system to the Fuel Pro Heater Base (see Figure 1). Either heater port will work as an inlet. Route another hose from the Heater Base to a low pressure port in the coolant system. **DO NOT** route into the cab heater system.

Optional Electric Preheater

The Electric Preheater can be used with heated systems such as the ones described above or with unheated systems. To install, follow the wiring diagram in Figure 3.

Note: When wiring the Electric Preheater, use a fuse **NOT** a circuit breaker.

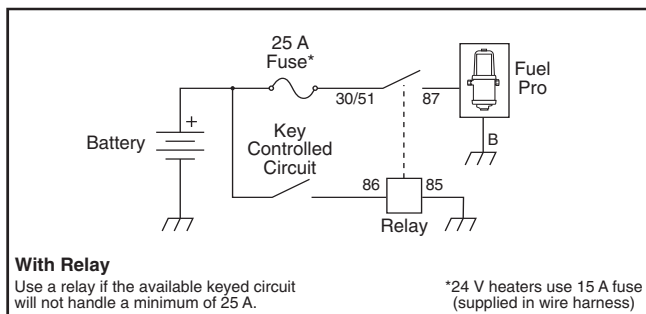
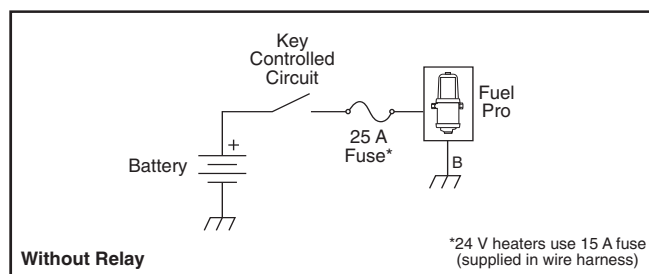

Figure 3 - Heater Wiring Options

Filter Change Procedure

Step 1 - Drain the fuel level to below the collar.

Step 2 - Check to make sure the drain valve at the base of the Fuel Pro is closed.

Step 3 - Using the Collar/Vent Cap Wrench (part number 3944460 S), remove the clear cover from the fuel processor by removing the collar. Discard the o-ring from the base of the cover. (A new o-ring seal is supplied with the new filter.) Remove the

filter element from the Fuel Pro by pulling upward and twisting slightly. Be sure the sealing grommet is removed from the center stud.

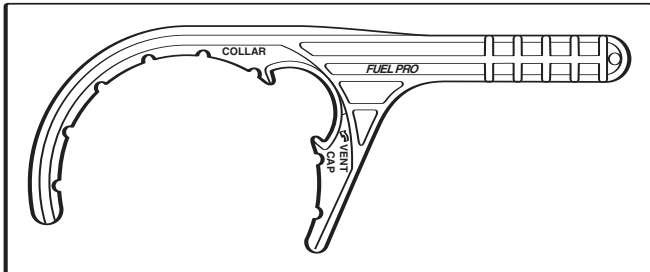

Figure 4 - Collar/Vent Cap Wrench

Step 4 - With the new filter (see Table 2) sealing grommet (supplied with the filter) inserted into the base of the filter element, install the element on the processor center stud. After checking to make sure the new o-ring seal (supplied with the filter) at the base of the cover is in place, install the cover, spring and collar. Hand tighten the collar until seated. **Do not use tools to tighten.**

Table 2 - Replacement Filters

Filter Part Number	Description
FS19761	Elemax™ Stratapore™ 2 micron
FS19624	Elemax™ Stratapore™ 7 micron
FS19729	EleMax™ Cellulose 50 micron
FS19728	EleMax™ Stratapore™ 25 micron
FS19727	EleMax™ Stratapore™ 10 micron

Step 5 - Remove the vent cap from the top of the clear cover by turning the vent cap counterclockwise. Fill the clear cover with enough clean fuel to cover the bottom half of the filter element. Make sure the new o-ring (supplied with the filter) is installed on the vent cap. Reinstall the vent cap and **tighten by hand only.**

Step 6 - Start the engine. When the lubrication system reaches its normal operating pressure, increase engine RPM for one minute.

Note: The clear filter cover will not fill completely during engine operation. It will gradually fill over time as the filter becomes clogged. The filter element does not need to be changed until the fuel level has risen to the top of the filter element.

Priming the System

Step 1 - Check to make sure the drain valve at the base of the Fuel Pro is closed.

Step 2 - Remove the vent cap from the top of the clear cover. Fill the Fuel Pro full of clean fuel. Reinstall the vent cap and **tighten by hand only.**

Step 3 - Start the engine. When the lubrication system reaches its normal operating pressure, increase engine speed to high idle for one to two minutes. After the air is purged, loosen the vent cap until the fuel level lowers to just above the collar.

Tighten the vent cap by hand only.

Note: The clear filter cover will not fill completely during engine operation. It will gradually fill over time and the fuel level will rise as the filter becomes clogged .

Step 4 - Hand tighten the collar again while the engine is running. **To avoid damage, do not use tools to tighten the collar.**

CAUTION: To avoid damaging the aluminum fuel processor body, do not overtighten fuel lines or fuel line fittings.

Emergency Temporary Filter Replacement

Step 1 - Follow Steps 1 through 4 of the "Filter Change Procedure" on page 3.

Step 2 - If there is a filter grommet on the filter stud, remove it.

Step 3 - Install an engine spin-on filter (partn number FF105, for example) on the threaded stud.

Step 4 - Install the cover, spring, seal and collar over the filter for later reuse and to guard against loss.

Step 5 - Start the engine. Raise the RPM for one minute to purge the air from the system.

Draining Contaminants

Step 1 - Turn off the engine and open the filter vent.

Step 2 - Place a cup under the drain valve at the base of the Fuel Pro and open the drain valve.

Step 3 - Water will flow into the cup. When fuel begins to flow out of the drain, close the drain valve. (Drain the minimum amount of fuel possible.)

Step 4 - Close the filter vent.

Step 5 - Start the engine. Raise the RPM for one minute to purge the air from the system.

Suggested Preventive Maintenance

Weekly - Drain water.

Every Filter Change - Change o-rings and grommet (included with new filter).

Every 12 Months - Check all electrical connections for corrosion. Check all fuel fittings for leaks.

Extreme winter or salt corrosion environments may require lubrication of the top collar threads with Loctite® 76747 antiseize every 180 days.

Ordering Information

Housing Part Number	Filter Element	Pre-Heater 1	Pre-Heater 2	Fluid Heat	WIF	Fuel Flow
FH23027	FS19624	12 VDC	120 VAC	Yes	N/A	In Right / Out Left
FH23028	FS19624	24 VDC	120 VAC	Yes	N/A	In Right / Out Left
FH23029	FS19624	N/A	N/A	N/A	N/A	In Right / Out Left
FH23030	FS19729	N/A	N/A	N/A	N/A	In Right / Out Left
FH23031	FS19624	12 VDC	N/A	N/A	N/A	In Right / Out Left
FH23032	FS19624	24 VDC	N/A	N/A	N/A	In Right / Out Left
FH23038	FS19624	N/A	N/A	Yes	N/A	In Right / Out Left
FH23039	FS19624	N/A	N/A	Yes	Yes	In Right / Out Left
FH23040	FS19624	12 VDC	N/A	Yes	N/A	In Right / Out Left
FH23041	FS19624	12 VDC	N/A	Yes	Yes	In Right / Out Left
FH23042	FS19624	24 VDC	N/A	Yes	N/A	In Right / Out Left
FH23045	FS19624	120 VAC	N/A	Yes	N/A	In Right / Out Left
FH23049	FS19624	12 VDC	N/A	N/A	Yes	In Right / Out Left
FH23050	FS19624	24 VDC	N/A	N/A	Yes	In Right / Out Left
FH23054	FS19624	12 VDC	120 VAC	N/A	N/A	In Right / Out Left

<p>3945145 S Heater Wire Harness, Metri Pack 3945123 S Heater Wire Harness, Weather Pack Upgrade Kits: 3944456 S 12 V-250 W Preheater Upgrade 3945193 S 24 V-250 W Preheater Upgrade Items Not Shown, 12 V: 3944450 S Fuel Heater Assembly 3945124 S Harness Kit, Weather Pack 3944455 S Harness Kit, Metri-Pack</p>	<p>Items Not Shown, 24 V: 3945136 S Fuel Heater Assembly Items Not Shown, 120 V: 3945121 S Fuel Heater Assembly 3945126 S Heater Cord Contact Fleetguard Customer Support for proper part number information.</p>
--	--

Dimensions

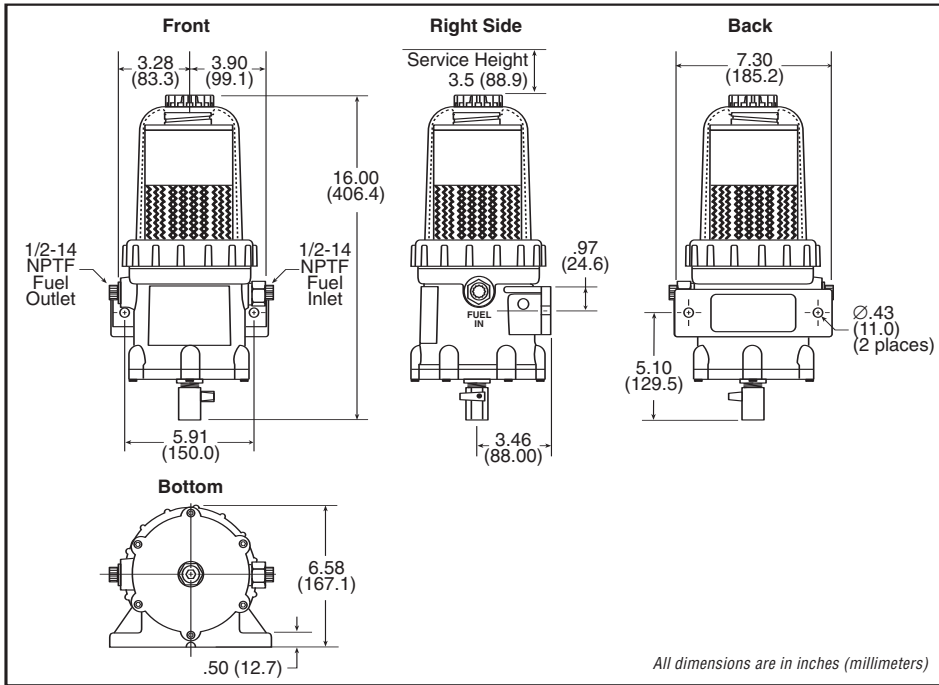

Fleetguard Fuel Pro[®] 230 Series Specifications

Height Overall	16.13" (409.7 mm)
Depth Overall	7.25" (184.15 mm)
Width, max	6.89" (175 mm)
Mount Bracket Centers	5.91" (150.11 mm)
Weight (Dry)	7.25-9.75 lbs (3.9 - 4.42 kg)
Fuel Connection (Inlet)	1/2"-14 NPTF
Fuel Connection (Outlet)	1/2"-14 NPTF
Fluid Heat Connection (Inlet)	1/2" NPTF
Fluid Heat Connection (Outlet)	1/2" NPTF
Fuel Capacity (w/ filter)	64.2 oz (1.9 L)
Operation Fuel Flow Rate	150 gph (568 lph)
Recommended Application	Heavy Duty Engines
Water Trap Capacity	33.8 fl oz (1.0 L)
Filter Replacement	FS19624*
Filter Service Clearance	Min. 3.5" (88.9 mm)
Electrical Heater	12 VDC, 250 W, 18 A \pm 3 A 24 VDC, 250 W, 11 A \pm 2 A 120 VAC, 75 W, .65 A \pm .1 A

* Other filter options at different Micron Ratings are available. Specifications subject to change without notice.

FH230 Series Restriction vs Flow

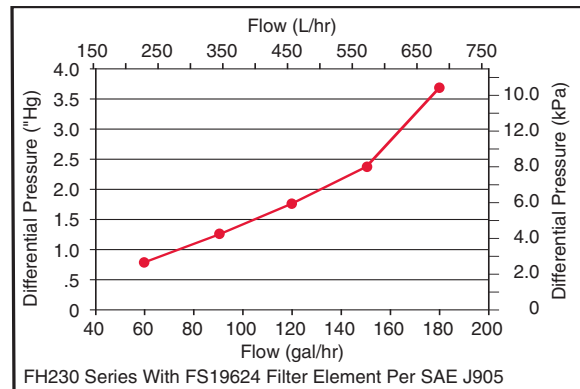

Filter Restriction vs Capacity

